

ACCELEROMETERS AND DATA WIRELESS TRANSMISSION

Tomas KOPECKY, Doctoral Degree Programme (1)
Dept. of Control and Instrumentation, FEEC, BUT
E-mail: xkopec13@stud.feec.vutbr.cz

Miroslav KRUPA, Doctoral Degree Programme (1)
Dept. of Control and Instrumentation, FEEC, BUT
E-mail: xkrupa03@stud.feec.vutbr.cz

Supervised by: Dr. Ludvik Bejcek

ABSTRACT

The paper describes wireless data transmission from accelerometers placed under trucks and other vehicles. A new universal system for measured data wireless transmission was designed. Accelerometers of ADXLxxx series produced by Analog Devices Inc. and radio transceiver AC4486 of Aerocomm are used. The possibility and usage of wireless data transmission are completely described. Results of this work are utilized for car testing at the Department of Machines and Engines at the Faculty of Mechanical Engineering of BUT. The designed system is suitable for all-purpose wireless data measuring.

1 INTRODUCTION

Acceleration measurement is used in many branches of industry in the range of heavy machinery to inertial guidance system navigation in car industry. Analog Devices Inc. developed monolithic integrated sensors of acceleration series ADXLxxx after increase of demand for accelerometers. Choosing sensors and their application is just a first step in the whole chain of a measuring. Data transmission and processing to PC is necessary after measured data was obtained and digitalized. Conductive transmission is complicated and unfavourable in many cases. Moving a measured object, a mobile measuring station or indirect connection between operator and sensor (heavy industry, chemical industry) could be mentioned for example.

Sensors placed under a vehicle moving on a testing road surface, and a human operator sitting in operator's centre is one of a typical application. Usage wireless data transmission is only one possibility how to realize measurement in this case. Similar problem was found at Faculty of Mechanical Engineering (FME) of BUT. This work brings transparent description of universal solutions, which could be applied for measuring any quantities. Next chapters will analyse the whole situation.

2 THE MEASURING CHAIN

A design of system for measuring acceleration from six sensors was basic requirements of FME. The measurement should be in the range of 0 g to 2 g in one an axe with minimum resolution 0.1 g. The bandwidth of measuring is 50 Hz and have to run in the real time. Data should be transmitted wirelessly from one collecting place under a vehicle to operator centre with PC. Project was extended to several cooperating modules after consultation. Flexible system was created, which is easily applicable for wide range real application with minimum requirements for restructuring. A measuring chain on truck's axle could be seen at fig. 1.

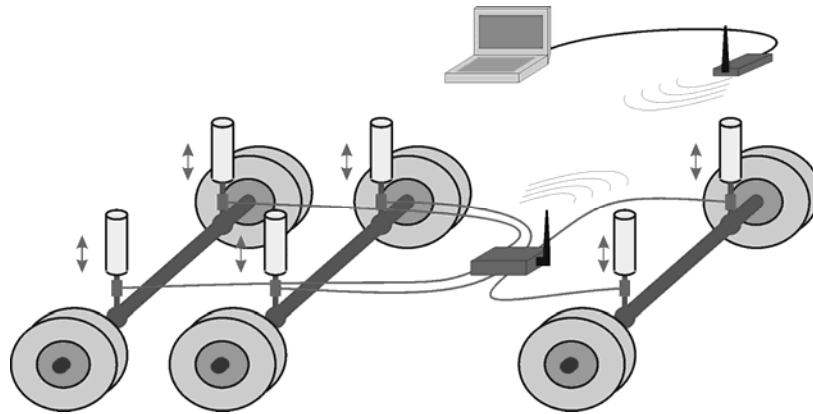

Fig. 1: Chain of measuring and its illustrational scheme

Accelerometers ADXL202 are fixed in aluminium and mechanical resistant case. The case is connected to a data logger central by electrical cable. The central provides radio data transmission using Aerocomm AC4486 modules. Receiver with USB interface and a PC is on the other side. An Li-Ion battery is used for power supply of central of measuring. Receiver is supplied from PC by USB port. Solutions of each part will be described in next chapters.

2.1 ACCELEROMETERS ADXL202 [1]

Sensors of Analog Devices Inc. was chosen in our work. The ADXL202/ADXL210 are low cost, low power, complete 2-axis accelerometers with a measurement range of positive and negative 2 g. The ADXL202 can measure both dynamic acceleration (e.g., vibration) and static acceleration (e.g., gravity).

The outputs are digital signals whose duty cycles are proportional to the acceleration in each of the two sensitive axes. These outputs may be measured directly with a microprocessor counter. The output period is adjustable from 0.5 ms to 10 ms via a single resistor. If a voltage output is desired, a voltage output proportional to acceleration is available from the filtering pins, or may be reconstructed by filtering the duty cycle outputs.

Resolution	$\pm 2 g$
Bandwidth	0,01 Hz – 5 kHz
Typical Noise	$500 \mu g/\sqrt{Hz}$
Temperature Range	0 °C to +70 °C
Voltage Supply/Current Consumption	3 – 5,25 VDC / 1 mA

Tab. 1: Basic technical specification

The ADXL202 are acceleration measurement systems on a single monolithic integrated circuit. They contain a polysilicon surface micro machined sensor and signal conditioning circuitry to implement an open loop acceleration measurement architecture. Polysilicon springs suspend the structure over the surface of the wafer and provide a resistance against acceleration forces. Deflection of the structure is measured using a differential capacitor that consists of independent fixed plates and central plates attached to the moving mass. The fixed plates are driven by 180° out of phase square waves. Acceleration will deflect the beam and unbalance the differential capacitor, resulting in an output square wave whose amplitude is proportional to acceleration. Phase sensitive demodulation techniques are then used to rectify the signal and determine the direction of the acceleration.

For each axis, an output circuit converts the analog signal to a duty cycle modulated (DCM) digital signal through a resistor, that is decoded with a AVR microprocessor. There is a pin available on each channel to allow the user to set the signal bandwidth of the device by adding a capacitor. This filtering improves measurement resolution and helps prevent aliasing. After being low-pass filtered, the analog signal is converted to a duty cycle modulated signal by the DCM stage. A single resistor sets the period for a complete cycle, which can be set between 0.5 ms and 10 ms.

2.2 MICROPROCESSOR AVR ATTINY2313 [2]

AVR microcontroller of ATMEL was chosen for its low-cost and easy code evaluation. The ATtiny2313 is a low-power CMOS 8-bit microcontroller based on the AVR enhanced RISC architecture. By executing powerful instructions in a single clock cycle, the ATtiny2313 achieves throughputs approaching 1 MIPS per MHz allowing the system designer to optimize power consumption versus processing speed. The AVR core combines a rich instruction set with 32 general purpose working registers. All the 32 registers are directly connected to the ALU, allowing two independent registers to be accessed in one single instruction executed in one clock cycle.

The ATtiny2313 provides the following features: 2 Kbytes of In-System Programmable Flash, 128 bytes EEPROM, 128 bytes SRAM, 18 general purpose I/O lines, 32 general purpose working registers, a single-wire Interface for On-chip Debugging, two flexible Timer/Counters with compare modes, internal and external interrupts, a serial programmable USART, Universal Serial Interface with Start Condition Detector, a programmable Watchdog Timer with internal Oscillator, and three software selectable power saving modes. The Idle mode stops the CPU while allowing the SRAM, Timer/Counters, and interrupt system to continue functioning.

2.3 WIRELESS TRANSMISSION WITH AC4486 [3]

AeroComm's compact 868 MHz transceivers can replace cable in harsh environments. Using field-proven FHSS technology which needs no additional ETSI (Europe) licensing, OEMs can easily make existing systems wireless. The modules operate in a point-to-point or point-to-multipoint, client/server or peer to peer architecture.

AeroComm's embedded transparent protocol simplifies the OEM's integration process by allowing for drop-in installation. As each transceiver receives raw data, it manages over-the-air protocol to assure successful communication. Headers, data packet length, and CRCs are not needed. RF-232 supports point-to-point or point-to-multipoint, client/server or peer-to-peer configurations. Broadcast communication to all transceivers or address packets to a

specific destination using unique MAC addresses embedded in each transceiver.

There are two protocol modes on radio: Acknowledgement mode and Streaming mode. In acknowledgement mode, transmitted packets are successfully acknowledged. If not, they are resent until successful. Error detection is used and duplicate data is filtered out before sending to the host interface. Optional full duplex control setting allows equal time for transmitting and receiving data at the RF level, keeping a single transmitter from dominating the system bandwidth. Streaming mode is useful for audio or other applications where continuous data is needed. Data is transferred to the host without error-detection.

3 THE FINAL SOLUTION

ADXL202 sensors placed in a mechanical resistance case are the main part of the system. Both duty-cycle signals and power supply are connected to data logger through shielded cable. Actual axis is chosen inside data logger via switch. Chosen signals are connected to PORT B pins of ATtiny2313 microprocessor for forward processing. See fig. 2, which shows schematic diagram of measuring system.

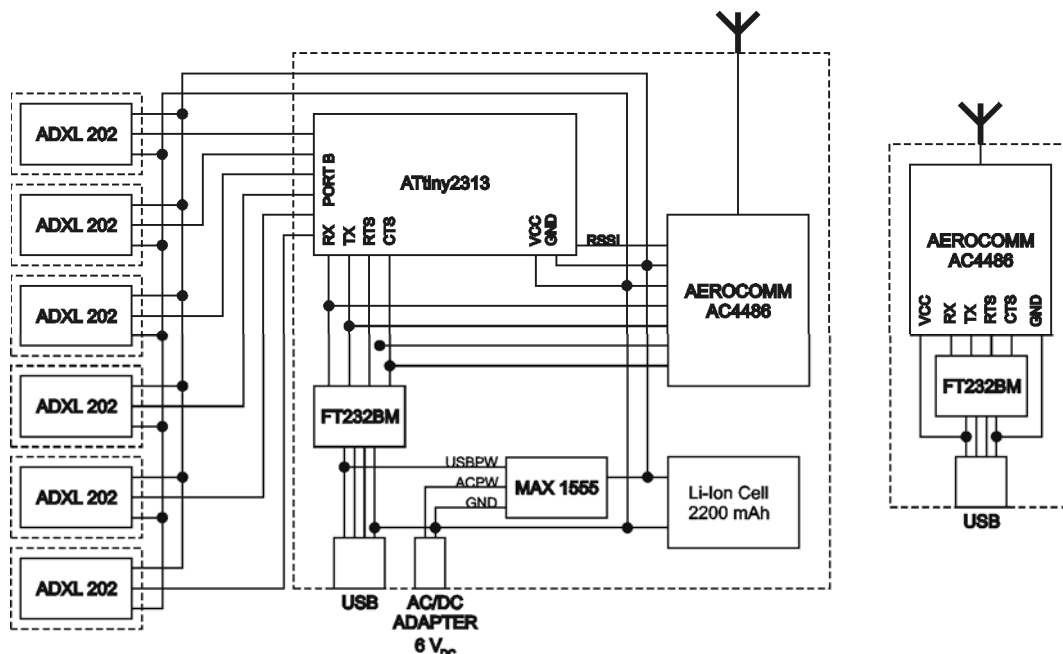

Fig. 2: Schematic diagram of measuring system

Sensors output signal duty-cycle measurement is basic problem. External interrupt reacting on edge is usual for one, two or three sensors. For six sensors is this solution inappropriate because of increase of hardware and price requirements. Way of timer interrupt of microprocessor has been chosen after some discussions. An interrupt service routine continuously reads all eight signals on PORT B. All sensors have the same period of the output signal T_2 . Right the period of the timer is way of correcting and setting the measurement precision. Interrupt frequency determinate sensors sensitivity. Relation between sensitivity, PWM frequency and bit resolution is shown in example below.

If output sensor period is $T_2 = 10 \text{ ms}$, sensor sensitivity is $S=12.5 \text{ \%/g}$, measurement range is $R= \pm 2 \text{ g}$ i.e. $|R|=4 \text{ g}$ and required resolution is 10 b. T_2 have to be divided to $T = T_2 \cdot |R| \cdot S / 100 = 10 \cdot 10^{-3} \cdot 4.0 \cdot 12.5 = 5 \text{ ms}$ i.e. 1024 levels. That means, timer interrupt have to

be caused every $T_{interrupt} = T/1024 = 4,88 \mu s$. Instruction cycle of ATtiny2313 is $T_{instruction} = 100 ns$. Interrupt routine can not be longer then $n = T_{interrupt} / T_{instruction} = 2,44 \mu s / 100 ns \approx 50$ cycles. That is possible. Resolution of sensors is approximately 4mg in this case.

Reading the PORT B value as 8 bit number and comparing it with the previous value is done in the interrupt service routine. Number of interrupt is saved as a 16b number and state of PORT B is saved as 8 bit number in case of the change. The different state have to occur every 18 times to read the whole duty-cycle from all sensors. Obtained data are sent out of processor using UART. One of AD converters is used for measuring received signal strength of AC4486. Converted signal is sent with each data sequence. User therefore has actual information about signal strength. Serial data are wired to header connecting radio module AC4486. Header compatibility is a big advantage, so another module with integrated antenna or microwave frequency could be used. Serial data are also sent to FM232BM circuit which provided conversion from TTL to USB. USB connection is used as a backup in case a radio transmission failed. A battery power supply has to be inside the data logger. Lithium ion battery was chosen because of its low price versus capacity. MAX1555 as a stand-alone charger was picked out to keep lifetime of battery and control the charging sequence from the prequalification state through fast-charge, top-off charge, and full charge indication. Thermal-regulation circuitry is included for proper function. AC adapter or USB could be use as a source of power for charging a battery with MAX1555.

Just a radio module with FM232BM TTL to USB converter is on the PC side. USB interface is used also as power supply. Spikes from USB supply are filtrated via decoupling caps.

4 CONCLUSIONS

Developing and realizing data wireless transmission from six ADXL202 accelerometers was the main aim of this work. The modular conception has been designed because of it's simply reconfiguration of some parts. The data logger based on ATtiny2313 has been developed. Capturing data and wireless transmission via the radio module Aerocomm AC4486 is provided. The USB connection is used as a backup, but also as a possibility to charge the Li-Ion battery. The MAX1555 circuit is used for proper recharging and a battery protection. Received signal strength is transmitted with data for easier control. A simple USB connected to the radio module is on the side of the computer. This conception has been successfully tested at the Department of Mechanical Engineering of BUT. Accuracy of 10 bit has been continuously reached in the measuring range $\pm 2 g$ with 50 Hz boundary frequency.

REFERENCES

- [1] Analog Devices. Low Cost $\pm 2 g / \pm 10 g$ Dual Axis iMEMS® Accelerometers with Digital Output.[on-line]
http://www.analog.com/UploadedFiles/Data_Sheets/70885338ADXL202_10_b.pdf
(3.2.05)
- [2] Atmel. ATtiny2313/V Preliminary Summary.
[on-line] http://www.atmel.com/dyn/resources/prod_documents/2543S.pdf (3.2.05)
- [3] Aerocomm, ConnexRFTM AC4486.
[on-line] http://www.aerocomm.com/Docs/User_Manual_AC4486.pdf (3.2.05)