

MULTIFUNCTIONAL MODULE FOR MEASURING OF WATER PARAMETERS USING CLASSICAL GLASS PROBES

Ing. Zdeněk HAVRÁNEK, Doctoral Degree Programme (1)
Dept. of Control and Instrumentation, FEEC, BUT
E-mail: xhavra04@stud.feec.vutbr.cz

Supervised by: Dr. Ludvík Bejček

ABSTRACT

This work deals with theoretical design and description of practical realization of the module for water parameters measuring. The base for theoretical design was in theoretical knowledge of possibility and methods of measuring of each parameter. The gained knowledge was later used in practical construction and debugging of the module and in checking of selected parameters in real working environment.

1 INTRODUCTION

Using classical glass probes (electrodes) for measuring of water parameters, such as pH, red-ox potential, concentration of dissolved ions, is still advantageous with respect to relative low prices of these probes compared with advanced sensors using principle of ion sensitive field effect transistor (ISFET) or conductivity sensors without electrodes [3], [4], [5].

But the disadvantage of this solution is in rather complicated processing electronic which must satisfy very strict criteria on input parameters in many cases (e.g. very high input impedance in potentiometric measurements). The general disadvantage of classical solution consists in holding same parameters of these probes during utilization. During periodic calibration (usually several times a month) the dirt can be removed from classical probe or the probe can be replaced by new one if there is total decrement of sensitivity. This solution is still cheaper than using modern probes.

The objective of this work was exploring of possibilities and designing of the measuring module containing specific input circuits for conversion signals from classical probes, a microcontroller with A/D converter for processing measuring data, a display and a circuit for communication with a superior system. The module could store measuring data to its internal memory and it can send measured values on request of another system (e.g. PC) connected through serial interface.

In the circuit there is given emphasis on minimum analog adjusting elements that's why every part is selected in accordance with respect to no calibration requirement of measuring chain except digital calibration in microcontroller and to guarantee the temperature stabilization of the whole device.

2 CONCEPTION OF THE MEASURING MODULE

The measuring module contains these five main parts:

- The core of the module is the microcontroller (MCU) Texas MSP430F148 with the integrated 12-bit A/D converter. The MCU was chosen with respect of low power consumption and many user-configurable pins.
- The large analog part for conversion signals from probes. Particular design is described below.
- Circuits for physical layer of serial interface.
- The displaying and operating part. For displaying measured values on the module there was used the LCD with LED backlight. The display itself has very low power consumption and the backlight can be disabled by controls on the module or externally by the USB interface to decrease total consumption and for longer battery life (backlight is one of that parts which consumes substantive quantity of supply current). Choosing of functions on the module is provided by five buttons which changes their function according to position in the displayed menu.
- The power supply. Energy utilization from three sources – from batteries placed inside the module, supply from external adapter and from serial interface.

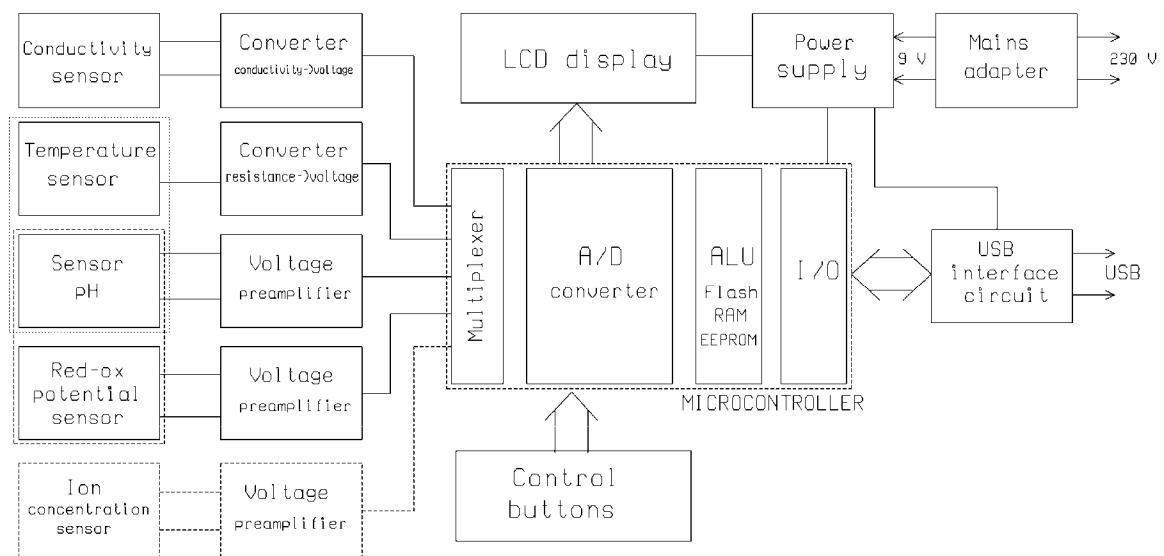

Fig. 1: The block diagram of the whole measuring module

3 CONVERSION OF ANALOG SIGNALS FROM PROBES

As it has been already noted above, for measuring water parameters (pH, red-ox potential and conductivity) there were utilized classical probes, which require specific circuits for conversion input signals. As it is shown in [1] and [2], for potentiometric measurement, such as measurement of pH (concentration of hydrogen), red-ox potential and eventually other dissolved ion, it is necessary to use the amplifier (the buffer) with very high input

impedance (for accuracy better than 1% there must be input impedance in tens till hundreds of G Ω - input current of the amplifier lower than 10 pA).

The quadruple operational amplifier LMC6484 fulfils these conditions, which has indicated input current in its entire temperature limit max. 4 pA (typically 20 fA) and it is possible to use single +5 V supply. Its inputs and outputs are the Rail-To-Rail type, which makes possible to use the whole supply voltage range (it is necessary for measuring red-ox potential).

Achievement of high input impedance is strengthened by using so-called the Guard-Ring on the printed circuit board, which inhibits leakage of undesirable stray currents and disturbance into non-inverting input of the amplifier. The input amplifier is then wired like non-inverting amplifier with gain of one. Output of the LMC is connected to the amplifier AD8544, where aren't so high requirements on input impedance, but on temperature stability and on big peak-to-peak amplitude of voltage on both input and output (Rail-To-Rail). This amplifier amplifies output voltage from first stage (LMC6484) in such a way that the possible voltage range from probes equals such output voltage which corresponds with input voltage range of the A/D converter.

The LMC6484 and AD8544 are quadruple operational amplifiers that's why they could be used for measuring of four various parameters - in the suggested solution they are used for measuring pH, red-ox potential and universal input for ion concentration. Designed circuits like this are capable to processing pH value in the range 0 till 14, red-ox from -2000 mV to +2000 mV and ion concentration which corresponds with voltage from -2000 mV to +2000 mV.

The circuit for evaluation of electrolytic conductivity of the solution contains the AC current generator with programmable output amplitude, the differential amplifier and the analog full-wave rectifier in comparison with a relative simple circuit for potentiometric measurement. Measurement of conductivity is provided by indirect method, when the amplitude of AC current with triangular curve is set and measured (this current flows through the conductivity probe (cell)) and voltage is measured on the conductivity cell by the differential amplifier and rectified in the next stage. Input voltage which controls AC current supply is also rectified and evaluated (this determinates the amount of current which flows through the probe) to determine possible changes of amplitude of output voltage from the generator due to temperature drift of amplifiers in the generator and also when the frequency of measuring current frequency is changed (as described in [2], there are usually required two measuring frequencies: 50 Hz – for low conductivity and 2 (4) kHz – for high conductivity). The amplitude of current from AC current supply can be chosen of four possibilities by analog switches in such a way that the whole range of measured conductivities (10 μ S to 100 mS) is divided into four sub-ranges to increase accuracy.

In voltage generator with triangular curve and in the full-wave rectifiers there are used operational amplifiers (OA) from Texas Instruments with name TCL2272 and for switching the sub-ranges there are used two analog switches ADG712 by Analog Devices. In a current supply there is single OA LTC1050 by Linear Technology and in differential amplifier there are two OAs both in one LT1112 also by Linear Tech. All parts are chosen in such a way to provide high temperature stability and accuracy (below 0,5%) of the whole measuring channel for temperature range from +5 $^{\circ}$ C to +45 $^{\circ}$ C.

One small part of the measuring module using one operational amplifier LTC1050 converts the temperature value to the voltage. As a sensing element is used platinum resistance thermometer Pt1000 which is through-flowed by the constant current (500 μ A) and an established voltage is sensed. Temperature is important for temp. compensation of pH and conductivity values.

4 COMMUNICATION INTERFACE AND POWER SUPPLY CONCEPTION

As a communication interface for the measuring module there was selected the serial interface called the USB. The USB is presently the most widespread hot-plug serial interface for PCs and the second great advantage is that it provides relatively strong power supply so it can be used as main supply for the module, when the superior system is downloading the data from the module. In more and more laboratories and industrial applications there are used PCs for analyzing measured data so the module could be supplied this way. The physical layer of USB interface provides the converter from classical serial interface integrated in the MCU (with TTL or LVTL voltage levels) to the USB – the integrated circuit from FTDI Chip called FT232BM. The converter is configured by the EEPROM memory which is connected to the main chip. This memory can be modified through the USB as well as the program for main MCU. The advantage of using the USB interface is described above and it is a presence of supply voltage of +5 V with continues output current up to 1 A. This amount of current is also sufficient for recharging the internal NiMH batteries when the modul is connected with a PC and the supply self module simultaneously. When the batteries are totally discharged there is another possibility of supplying the module – the using of external adapter with voltage from +9 V till +12 V (also doing the recharging of batteries). Making the module possible to work with battery supply is only due to low power consumption of the analog circuit, the MCU, the LCD (if the backlight is disabled) and the control circuit of the USB bus, which is going to sleep mode (with low consumption) always if there aren't any activity on the bus. The consumption of the whole module (without backlight) is lower than 50 mA and could be also decreased by disconnecting unused analog sub-circuits in some applications.

On the USB bus there can be transferred data either in real time (in measuring process) or can be downloaded as a block after a long term when the module is used for continued monitoring of water parameters in treatment plant or in neutralization station (the monitoring period could be the whole day or week). After that the data could be stored to the mobile computer.

5 SOFTWARE FOR PROCESSING OF THE MEASURING DATA

The measurement and control software was programmed in ANSI C in development tool for MCU Texas MSP430F and provides corrections of values after the analog to digital conversion according to constants acquired in calibration procedure, performs digital filtration (averaging of 100 samples) and stores the data to internal memory of the MCU. The A/D converter uses external reference voltage 2,5 V due to poor temperature stability of internal reference so the acceptable input voltage range was determined. The software in the MCU also controls the calibration process of all measuring channels and instructs the staff during calibration (what standard solution should be used etc.). Switching between sub-ranges and choosing of measuring frequency in conductivity measurement is controlled from the MCU and can be automatic or manual.

For data acquisition from the module on the PC side there was used a simple application programmed in NI LabVIEW for the present, where actual measuring data can be acquired and in future there could be acquired stored data from previous term.

6 MECHANICAL CONSTRUCTION OF THE PROTOTYPE

The measuring module was constructed on three printed circuit boards. On the front board there are situated: the display, the control buttons and the MCU. On the top board there are: the circuit for USB, the triangle curve generator, the full-wave rectifier and the power supply. The rear board contains all analog circuits and parts for processing the signals from probes and there are also BNC connectors for connecting the probes. The view on the front panel and the uncovered module is on the fig. 2.

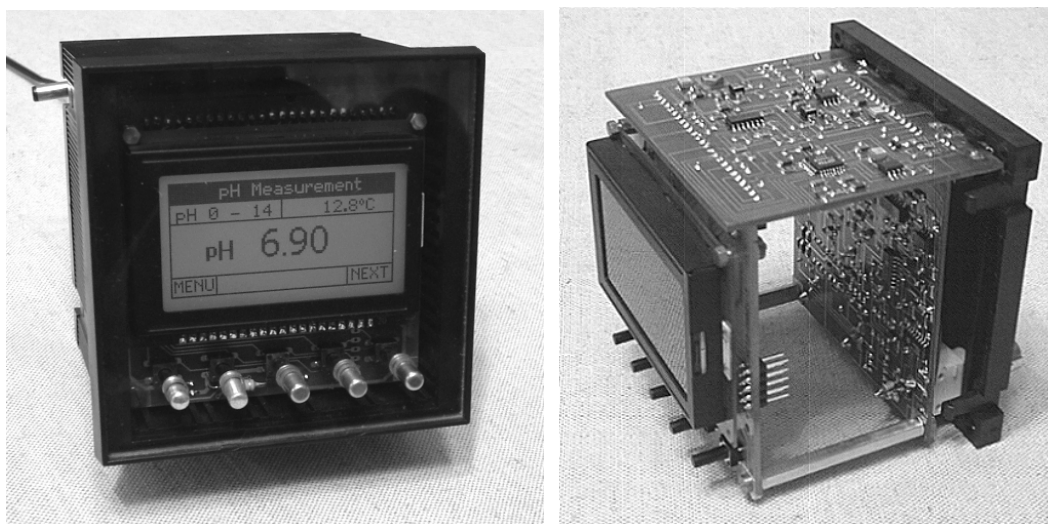

Fig. 2: *The front panel view of measuring module and the uncovered module*

7 CONCLUSION

The design of the measuring module describes the way of using the old type of water parameter sensing probes with the new available semiconductor parts and shows the advantages and disadvantages of this solution. The main advantage of this solution is the economic merit undoubtedly. On the other hand, the new sensing devices like ISFETs expect lower maintenance. The constructed prototype of measuring module is fully functional but some described functions haven't been implemented yet.

REFERENCES

- [1] Horáková, M., Lischke, P., Grunwald, A.: Chemické a fyzikální metody analýzy vod. 2. vyd. Bratislava: SNTL/ALFA, 1989. 392 s.
- [2] Kadlec, K.: Elektrochemické snímače. Automatizace 42, ISSN 0005-125X, 1999, č. 12, str. 901 - 905
- [3] Kabeš, K.: Přehled trhu – elektrochemické snímače a převodníky. Automatizace 42, ISSN 0005-125X, 1999, č. 12, str. 905 - 917
- [4] Měřicí technika pro laboratoře a životní prostředí. Weilheim: WTW, 1999. 256 s.
- [5] Laboratory products and electrochemistry handbook. Beverly: Orion, 1997. 112 s.