

# CARRIER PHASE RECOVERY FOR TURBO CODED SYSTEMS

Ing. Jan PROKOPEC, Doctoral Degree Programme (3)  
Dept. of Radio Electronics, FEEC, BUT  
E-mail: prokopec@feec.vutbr.cz

Supervised by: Prof. Vladimír Šebesta

## ABSTRACT

Turbo codes provide better BER (Bit Error Rate) at low SNR than other FEC (Forward Error Correction) codes, on the other side they have higher computational complexity. This is reason for design of algorithm for joint carrier recovery and turbo decoding. Carrier phase recovery of MQAM and MPSK modulation useful in Turbo coded systems is described. Phase recovery is based on Maximum-likelihood estimation and utilizes output of turbo decoder for Data-Aided synchronization, which provides accurate estimation of phase error of received signal.

## 1 INTRODUCTION

Sequences of independent identically distributed bits are coded by Turbo encoder. Turbo encoder consists from two RSCC (Recursive Systematic Convolutional Coders). Interleaved information bits are at the input of the second coder. The bits are mapped and modulated after coding. Modulator translates baseband signal to pass-band and it is transferred through the channel, which corrupts signal by complex additive white Gaussian noise with zero mean and variance  $\sigma^2$ . Signal to noise ratio is  $SNR = 1/2\sigma^2$ . Received signal can be expressed as

$$r(t) = s(t - \tau) + w(t), \quad (1)$$

where

$$s(t) = Re \left\{ s_{bb}(t) \exp(j2\pi f_c t) \right\}, \quad (2)$$

$s_{bb}(t)$  is baseband signal given by

$$s_{bb}(t) = \sum_k c_k g(t - kT), \quad (3)$$

where  $c_k$  are symbols from set of constellation and  $g(t - kT)$  is baseband impulse,  $T$  is symbol period and  $f_c$  is carrier frequency.

## 2 CARRIER PHASE RECOVERY ALGORITHM

Transmitted signal is corrupted by AWGN and by slow fading. Received signal represented by (1) can be rewritten as

$$r(t) = s(t; v, \theta, \tau) + w(t), \quad (4)$$

in vector form as

$$\mathbf{r} = \mathbf{s} + \mathbf{w}, \quad (5)$$

where  $v$  is frequency offset,  $\theta$  is phase offset and  $\tau$  is timing error caused by channel.

We assume:

- Phase offset  $\theta$  is equal  $\theta'$ ,
- frequency offset  $v$  is equal  $v'$ ,
- time delay  $\tau$  is equal  $\tau'$ ,
- transmitted data sequence  $\mathbf{c}$  is equal  $\mathbf{c}'$ .

Probability density function of  $\mathbf{r}$  is [4]

$$p_{\mathbf{r}|\theta, v, \tau, \mathbf{c}}(\rho|\theta', v', \tau', \mathbf{c}') = \mathcal{K} \exp\left(-\frac{1}{N_0} \|\rho - \mathbf{s}\|^2\right), \quad (6)$$

where

$$\mathcal{K} = \frac{1}{\left(\sqrt{2\pi \frac{N_0}{2}}\right)^K}, \quad (7)$$

$K$  is length of observation interval. We can write Likelihood function as

$$L_{\theta, v, \tau, \mathbf{c}}(\theta', v', \tau', \mathbf{c}') = \exp\left\{\frac{2}{N_0} \text{Re}[\langle \rho, \mathbf{s} \rangle]\right\}, \quad (8)$$

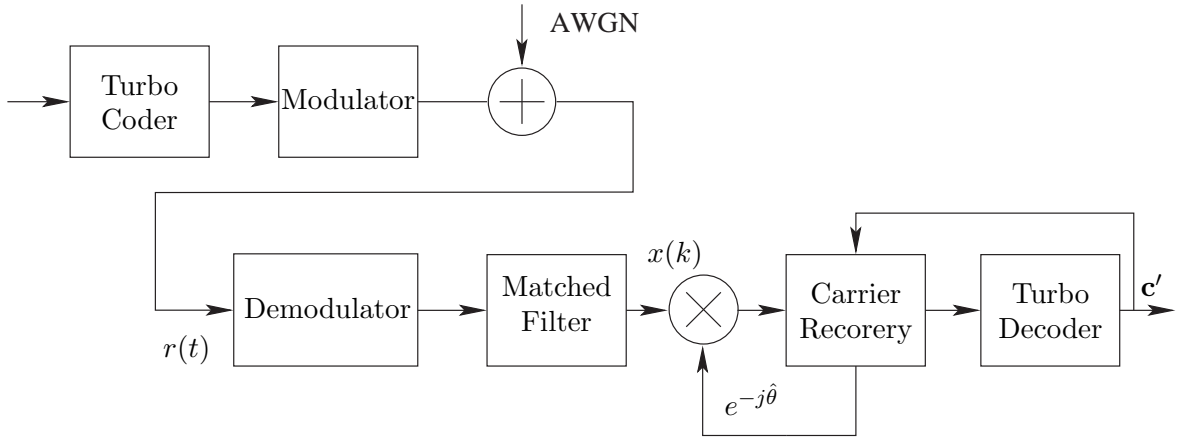

Figure 1: Block diagram of system with iterative synchronization

$\langle \rho, \mathbf{s} \rangle$  is inner product.

Assuming that frequency offset is equal to zero ( $v' = 0$ ), we have

$$L_{\theta, \tau, \mathbf{c}}(\theta', \tau', \mathbf{c}') = \prod_{k=0}^K \exp \left\{ \frac{2}{N_0} \text{Re}[c'_k{}^* x_k(\tau) e^{-j\theta'}] \right\}. \quad (9)$$

The Maximum likelihood estimation  $\hat{\theta}_{ML}$  depends on data sequence  $\mathbf{c}'$ .

$$\hat{\theta}_{ML} = \arg \max L_{\theta, \tau, \mathbf{c}}(\theta', \tau', \mathbf{c}^l), \quad (10)$$

where  $\mathbf{c}^l$  is output of turbo decoder in  $l^{\text{th}}$  iteration for data sequence  $\mathbf{c}'$ . Two approaches: MAP (*Maximum A Posteriory*) algorithm and SOVA (*Soft Output Viterbi Algorithm*) are suitable for iterative carrier recovery algorithm. Algorithms of turbo decoding are described in [1]. The basic principle of iterative decoder is shown in Fig. 2. Received sequence is decoded by inner decoder. Output of inner decoder is de-interleaved and decoded by outer decoder. Output of outer decoder is interleaved and fed-up to input of inner decoder. Feedback from outer decoder to inner decoder guarantees correct decoding and is used for Data Aided estimation of phase error. The first iteration uses Non-Data Aided synchronization, next iterations provide data sequence for synchronizer.

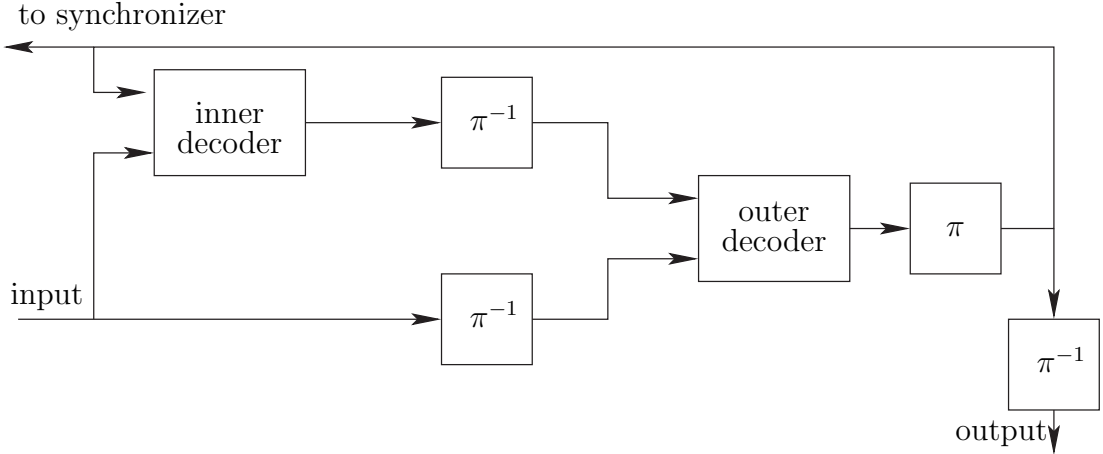

Figure 2: Block diagram of Turbo decoder

### 3 SIMULATION RESULTS

Simulation of carrier phase recovery with maximum likelihood estimation without iterative decoding is useful for Data-Aided synchronization, if the receiver has knowledge of transmitted data. The equation (9) for data aided estimation can be rewritten for QAM modulation as

$$l(\theta) = \sum_{k=1}^K \ln \left\{ \sum_D \exp \left( - \frac{1}{2\sigma^2} \|\mathbf{r}_k - \mathbf{d}e^{j\theta}\|^2 \right) \right\}. \quad (11)$$

The inner sum is over all constellation points and this is main disadvantage of this algorithm. It is not problem to compute the inner sum over all constellation points for small constellation (16QAM, 64QAM), but it is problem for large constellation (256QAM and over).

MLE of phase is angle  $\theta$ , which solves equation (12)

$$\frac{dl(\theta)}{d\theta} = 0 \Rightarrow \hat{\theta}_{ML}. \quad (12)$$

Equation (12) can be solved analytically, but for practical reasons is solved numeri-

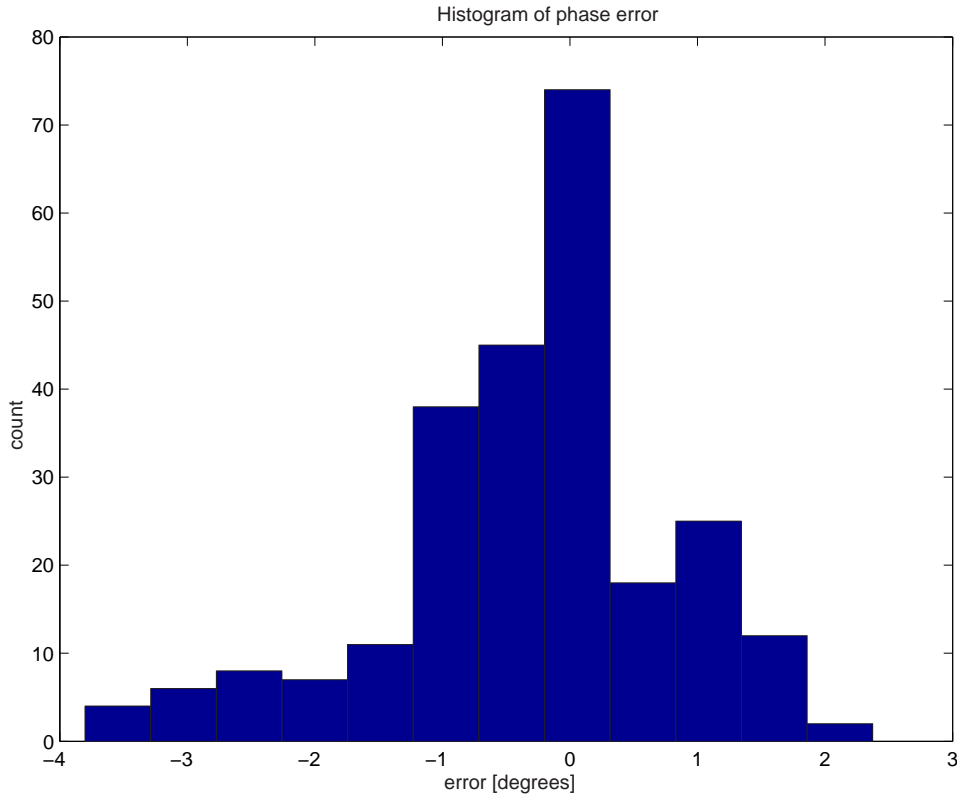

Figure 3: Histogram of phase error after synchronization, 64QAM

cally. Figure 3 shows results of simulation for 64QAM modulation. Synchronization system has MLE detector of phase error and CORDIC algorithm for phase rotation. Main advantage of CORDIC against DDFS (*Direct Digital Frequency Synthesizer*) is that only basic math operations - sum and multiply are used for phase rotation. DDFS needs *Look Up Table* of sine and cosine values in ROM memory. Transfer of values from ROM is slower than direct computing with CORDIC.

#### 4 CONCLUSION

This paper describes algorithm of carrier phase recovery, which can be modified and used for joint iterative decoding and synchronization in turbo coded systems. We

assume, that transfer protocol with special sequence is used, but in future work the output of turbo decoder will be used for data aided estimation and special packets for synchronization will be deleted. Future work will be focused on implementation of iterative principle to current algorithm and its implementation to DSP. Main interest is in low computation complexity of resulting algorithm.

## ACKNOWLEDGEMENT

This paper has been supported by the FRVŠ project No. 1628/2004, project GA ČR no. 102/03/H109 and project GA ČR No. 102/04/0557 “Development of the digital wireless communication resources”.

## REFERENCES

- [1] VUCETIC, B., YUAN, J. *Turbo Codes: Principles and Applications*. Norwel: Kluwer Academic Publishers, 2001. ISBN 0-7923-7868-7.
- [2] BURR, A. Turbo-Codes: the ultimate error control codes?. *Electronics & Communication engineering journal*. August 2001.
- [3] NOELS, N., STEEDAM, H., MOENECLAHEY, M. *Carrier Phase Recovery in Turbo receivers: Cramer-Rao Bound and Synchronizer Performance*. [www.telin.rug.ac.be/~hs/full/c34.pdf](http://www.telin.rug.ac.be/~hs/full/c34.pdf), january 2004.
- [4] BENVENUTO, N. CHERUBINI, G. *Algorithms for Communications Systems and their Applications*. Chichester: John Wiley & sons, 2002, ISBN 0-470-84389-6.